

ADC CONTROL FOR HOPPER BANKS

FEATURES:

The adaptation of the exclusive ADC control from DRI-AIR Industries to control the hopper bank systems allows the operator more options to select from. In addition to individual temperature control of each hopper, the new control has the following features:

- Individual temperature control of each hopper.
- On or off control for each hopper.
- Temperature setback for each hopper
- Temperature setting based on material selection.
- Individual timers for each hopper indicating length of drying.
- Log of events for easy troubleshooting.
- Individual high temperature alarms.
- Remote location of control panel.
- Display of all temperatures within system.
- Temperature calibration for each hopper.
- Selection of degrees F or C.
- Date and time indication with battery backup.
- Open thermocouple detection.

MAIN SCREEN:

The main operating screen is shown as follows:

Hopper *1 - On
Process 180F
Setpoint (180)
Drying Time 01:20:34

Asterisk * indicates setback mode has been actuated.

Parenthesis () indicates temperature has been set back.

Drying time in hours:minutes:seconds.

To display each hopper status, press arrow up or down.

OPERATION OF HOPPER BANK ADC CONTROL

DISPLAY OF HOPPER STATUS:

The display screen shows the status of each hopper in the bank. Each individual screen displays:

- Hopper number, setback on/off, hopper on/off
- Actual process temperature
- Setpoint and whether hopper is in setback or not
- Time material has been drying

To display each hopper status screen, use the arrow up ↑ or arrow down ↓ keys.

The main operating screen is shown as follows:

Hopper *1 - On
Process 180F
Setpoint (180)
Drying Time 01:20:34

Asterisk * indicates setback mode has been actuated.

Parenthesis () indicates temperature has been set back.

Drying time in hours:minutes:seconds.

SETTING THE TEMPERATURE:

- Press the TEMP SET button or MENU and arrow down key.
- Select the hopper that you want for a temperature change by selecting the correct number.
- Key in new value (the number will be flashing) and press ENTER.
- Repeat for other hoppers.

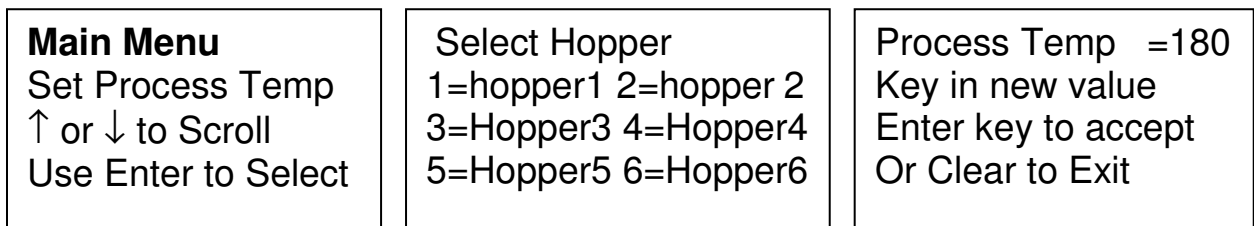

TO TURN A HOPPER ON OR OFF:

- Press MENU button and arrow down ↓ to the second screen
- Press ENTER, select hopper and press ENTER.
- Press 1 to turn hopper on and 2 to turn hopper off.

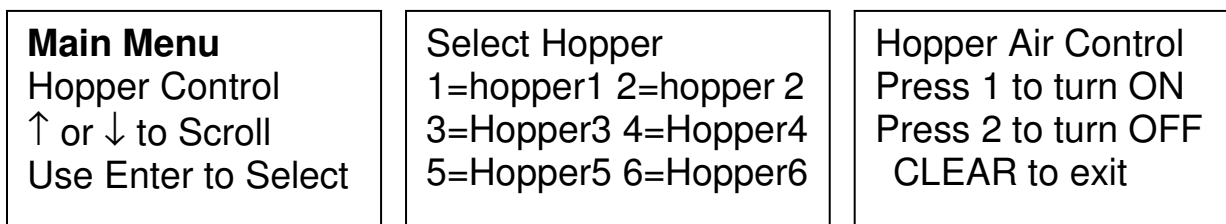

TEMPERATURE SETBACK SETTINGS:

The temperature setback feature prevents over drying of the material by reducing the process temperature after a period of time from start up of the hopper. Activation of this feature is indicated by an asterisk * before the hopper number on the main screen.

This screen allows the operator to turn on/off this feature, set a new setback delta, and input the time for drying.

- To select this feature, press the MENU button and arrow down ↓ to the SETBACK SETUP screen.
- Press ENTER, select hopper and press ENTER.
- To turn this feature on or off, press ENTER at the SETBACK ON OFF screen. Press 1 to turn on and 2 to turn off.
- To change the setback delta setting, press ENTER at the SETBACK DELTA screen. Key in new value and press ENTER.
- To change the drying time, press ENTER at the SETBACK INHIBIT screen. Key in new drying time in minutes and press ENTER. This time is adjustable from 10 to 360 minutes.

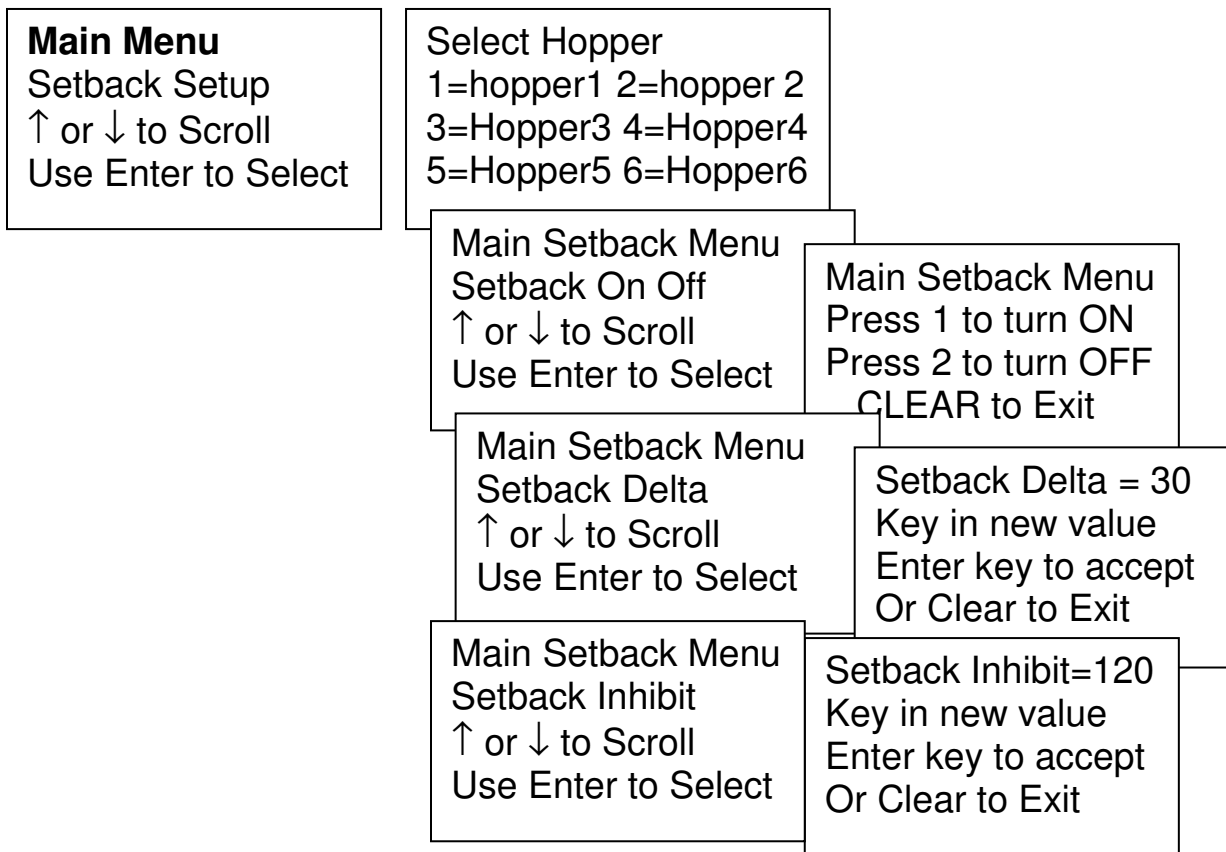

SYSTEM SETUP:

This screen is used to select between degrees F or C and to calibrate the temperature for each hopper.

To calibrate the temperature, remove the connector for the thermocouple in question. Place a standard in place of the thermocouple and read the displayed temperature. Enter the difference in the Temp Cal screen. A minus entry will display a lower temperature.

- Press the MENU button and arrow down ↓ to THE SYSTEM SETUP screen.
- Press ENTER to select SYSTEM SETUP
- Press ENTER to select Degrees F or C.
- Press 1 for degrees F and 2 for degrees C.
- Press ENTER to select.

To calibrate each hopper, scroll down from the Degrees F or C screen to the TEMP CALIBRATION screen.

- Press enter to select TEMP CALIBRATION.
- Select the hopper, press ENTER, and change the deviation required to calibrate the temperature and press ENTER. **The up and down arrows are used to make the change.**

LOADER SETTINGS:

If your hopper bank includes a loading system to load the molding machine, this screen allows changes to the load and delay time. The load time controls the amount of material sent to the receiver. The delay time allows time for the receiver to drop all of the material into the see through chamber.

- When in the SYSTEM SETUP screen, arrow down to Loader On Time and press ENTER.
- Key in the amount of load time in seconds and press ENTER.
- To change the delay time, arrow down to the Loader Delay screen and press ENTER.

- Key in delay time in seconds and press ENTER.

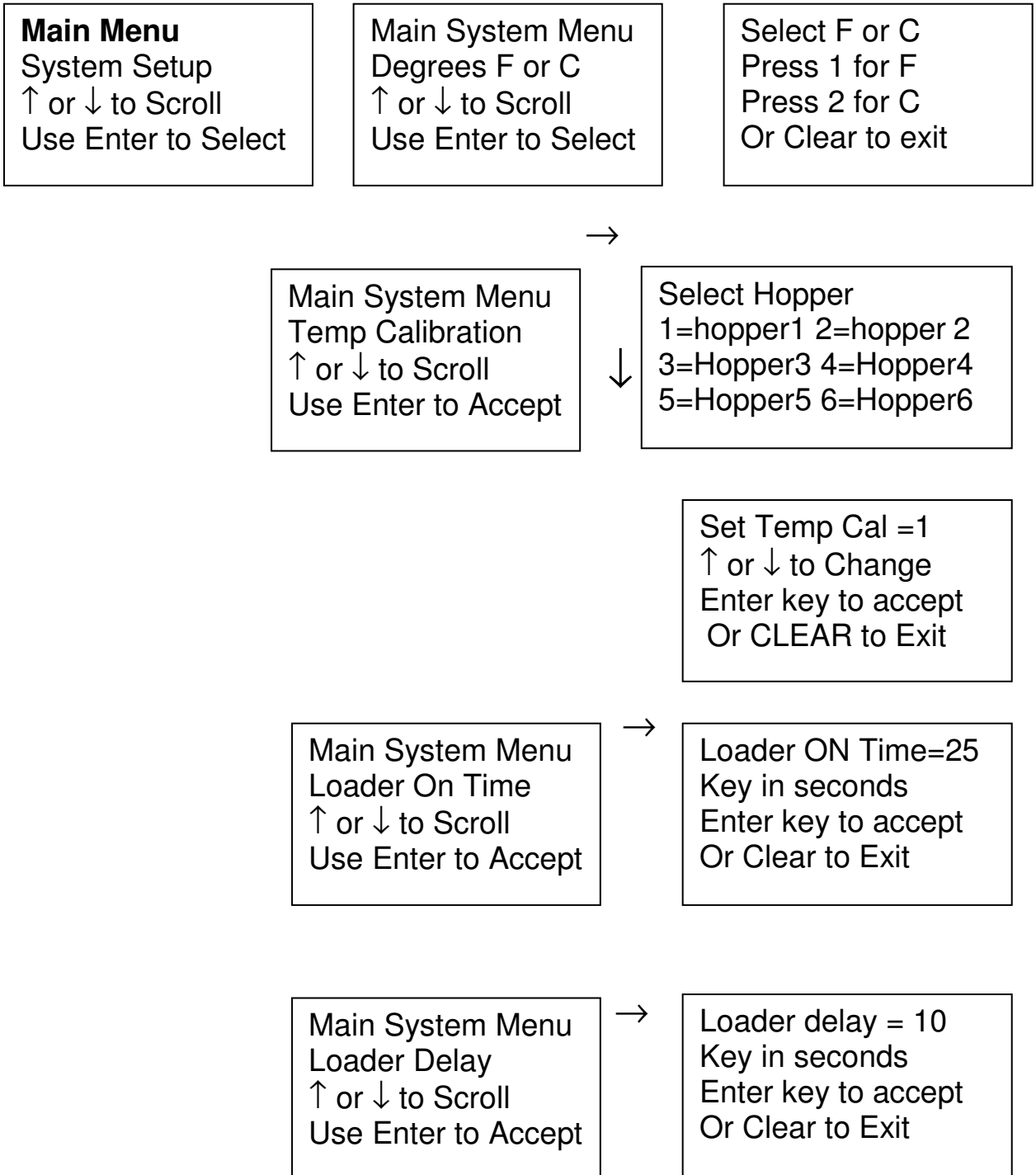

Main Menu
Factory Settings
↑ or ↓ to Scroll
Use Enter to Select

THIS SCREEN REQUIRES A
PASSWORD TO ACCESS AND
IS USED BY THE FACTORY ONLY.

DIAGNOSTICS:

This screen is used for trouble shooting a problem. The View Event Log shows the last 128 events and the time of the event. All temperatures can be accessed using the View Temps screen. The up and down arrows are used to access the different values.

- Press the MENU button and arrow down to the DIAGNOSTICS screen.
- Press ENTER to select.
- Press enter to select the event log. Arrow down to see the preceding events.
- Arrow down to the View Temps screen and press enter.
- Arrow down to see all thermocouple temperatures.

Main Menu
Diagnostics
↑ or ↓ to Scroll
Use Enter to Select

Main Diag Menu
View Event Log
↑ or ↓ to Scroll
Use Enter to Accept

Event Log
1= System Start
Thu 10:35
↑ or ↓ to Scroll

Main Diag Menu
View Temps
↑ or ↓ to Scroll
Use Enter to Accept

Temperatures
H1 Process = 180
↑ or ↓ to Scroll

ERROR MESSAGES

There are a few conditions that will cause an alarm condition. Check the following areas:

- Clean or replace return air filter. **Turn off the dryer while cleaning!** Blockage in this area will affect the performance of the dryer and hopper bank and may cause an alarm.
- Check that all hoses are connected and intact. Ground all material conveying hoses with the imbedded copper wire.
- Check the inlet and outlet of the hopper for proper airflow.

“P1 Hi Temp”

Indicates the dryer has been shut down because of a high temperature condition of the process heater.

- Check the airflow to the hopper in question.
- Check the solid-state relay for operation.
- Check thermocouples and connectors.

“Safety Error”

Indicates that the blower overload has tripped.

- Check the setting of the overload and condition of the blower.
- Check all 3 legs of incoming power.

“Air Pressure” Indicates no air pressure for those models that require an air supply.

- Check to make sure there is air supply to the dryer.
- Check pressure switch

“Loader Alarm”

Indicates the optional closed-loop loader has tried 3 times to load the receiver and no material has been loaded.

- Check to see if the material supply is adequate and all hoses are in the correct location.
- To reset the alarm after fixing the problem, either satisfy the proximity sensor or turn the main power off and back on“

“Repair Required” Indicates a failed heater or solid-state relay upon startup.

- Check all heaters and solid-state relays for proper operation

OPERATIONAL MENU SELECTION SUMMARY

Press MENU button and arrow down to access screens.
Press ENTER to access screens within a menu selection.

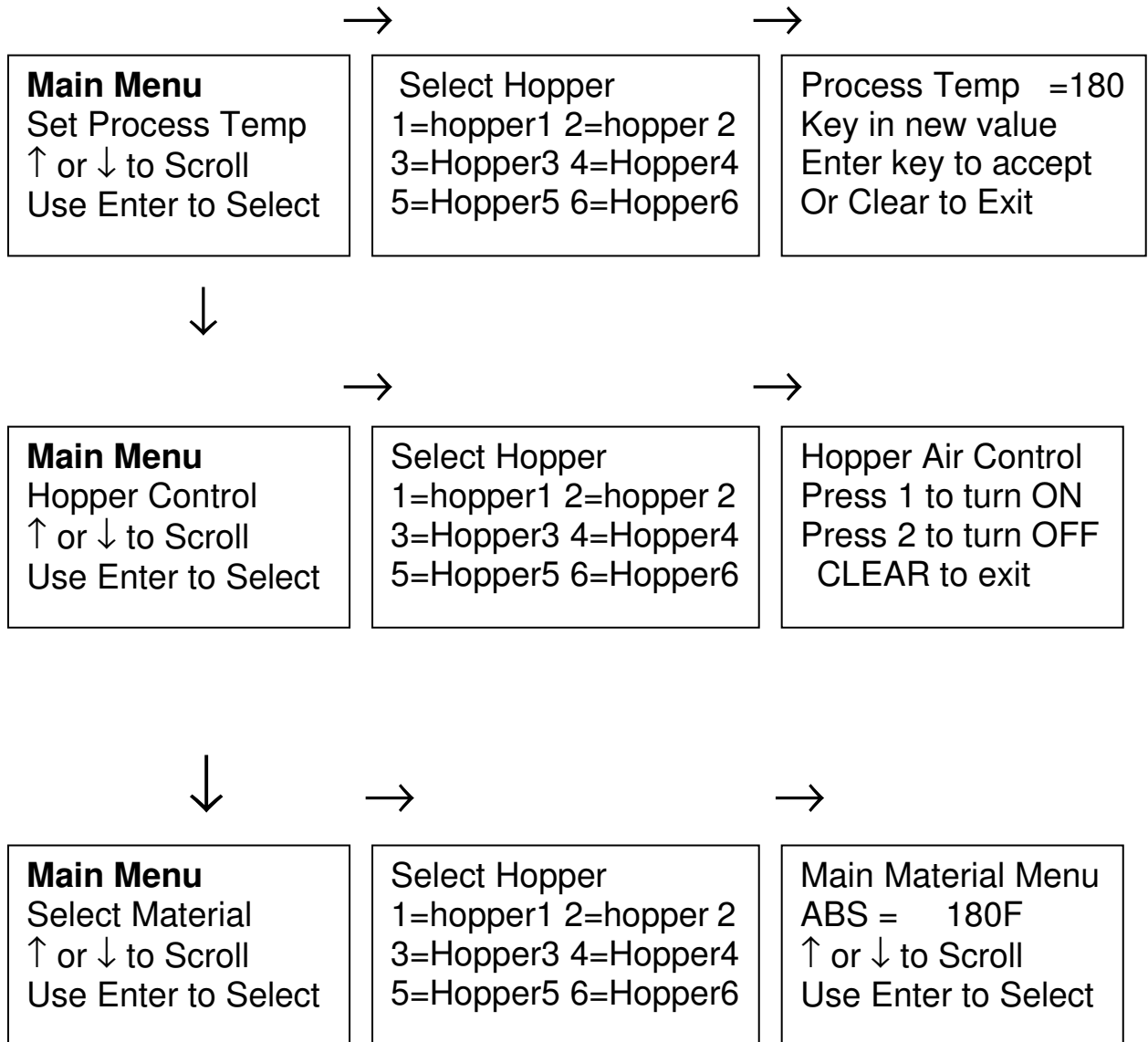

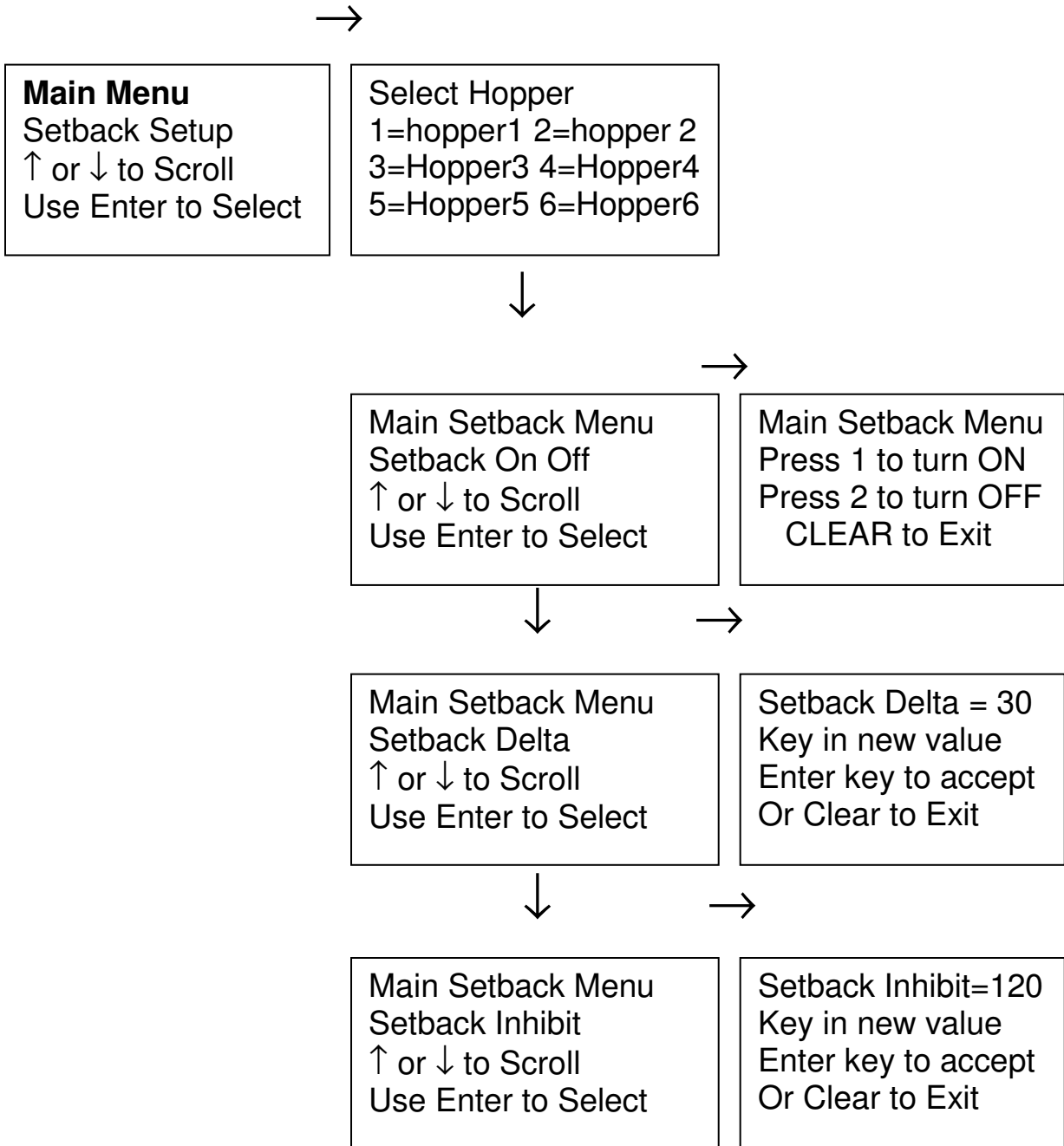

Main Menu
Seven Day Timer
↑ or ↓ to Scroll
Use Enter to Select

THIS SCREEN IS NOT USED FOR
HOPPER BANKS

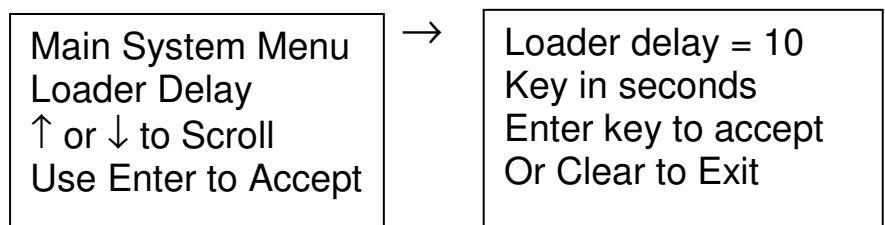
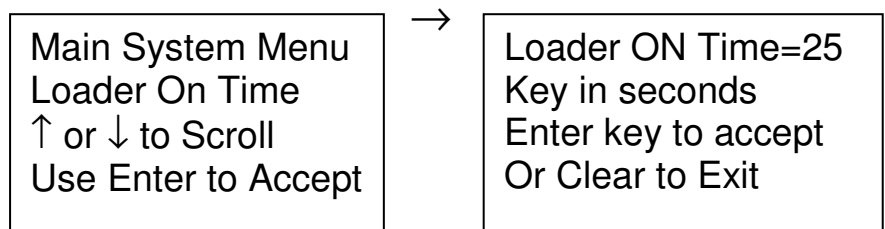
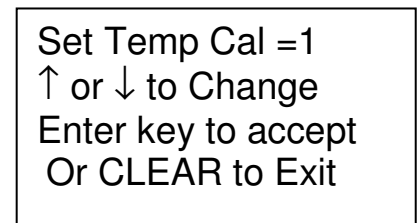
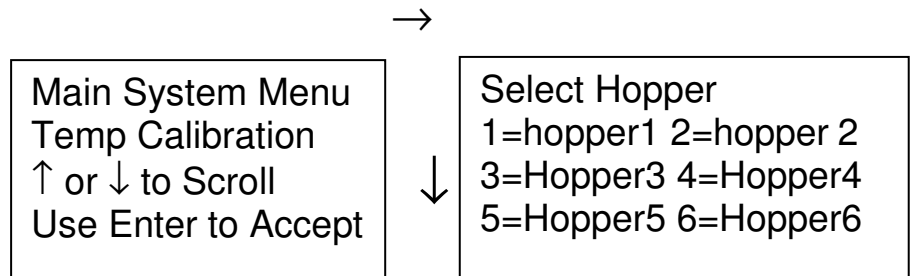
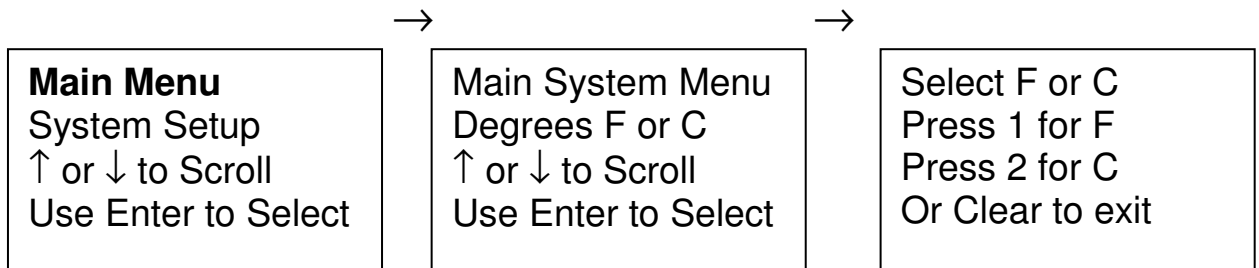
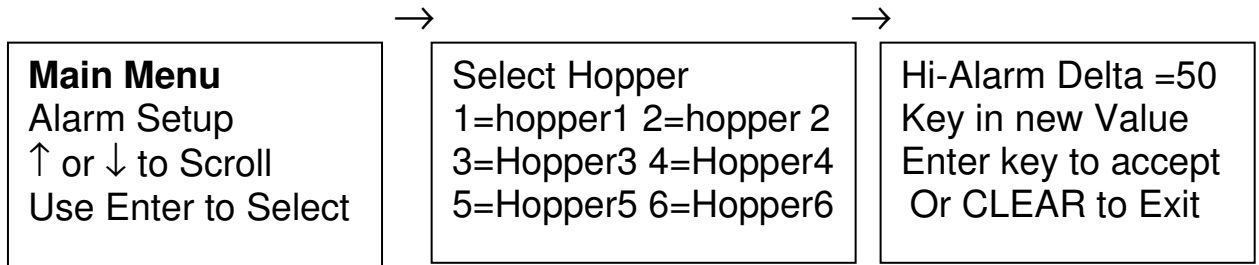

Main Menu
Factory Settings
↑ or ↓ to Scroll
Use Enter to Select

THIS SCREEN REQUIRES A
PASSWORD TO ACCESS AND
IS USED BY THE FACTORY ONLY.

Main Menu
Diagnostics
↑ or ↓ to Scroll
Use Enter to Select

Main Diag Menu
View Event Log
↑ or ↓ to Scroll
Use Enter to Accept

Event Log
1= System Start
Thu 10:35
↑ or ↓ to Scroll

Main Diag Menu
View Temps
↑ or ↓ to Scroll
Use Enter to Accept

Temperatures
H1 Process = 180
↑ or ↓ to Scroll

TEMPERATURE SETBACK THEORY

The optional temperature setback feature for the ADC control prevents over drying of the material due to excessive residence in a drying hopper at the suggested drying temperatures. This is especially true for Nylon, which can be over dried leading to degradation of the resin resulting in molding problems and brittle parts. It can also be useful in hopper bank applications to dry material to specific moisture levels.

When the temperature setback is actuated, a timer is started allowing the material to dry for a specified time. Once this time has expired, the return temperature from the hopper is compared to the process temperature using a thermocouple located in the return port of the hopper. If the return temperature is within a specified delta from the process temperature, the process temperature is reduced by the programmed setback delta. This indicates that the material has been dried and further drying is not required.

The process temperature is restored to the set temperature when the return temperature reaches 100 degrees F indicating new material has been added and needs drying. The process temperature will remain at the set temperature until the return temperature again reaches the delta from the setpoint. The process temperature will then be setback by the setback delta.

DEFINITIONS:

Setback Delta

The Setback Delta setting is the amount below the setpoint that the process temperature will be reduced by. If the process temperature is set to 250 F and the setback delta is set at 30, the setback temperature will be 220 F. Our experience has shown the factory setting of 30 for the setback delta is ideal for most resins.

Caution: Do not enter a Setback Delta that will reduce the setback temperature below 140 degrees F, as the dryer will not maintain temperatures below 140F.

Setback Inhibit

The Setback Inhibit setting is the time in minutes to dry the material before the setback can be initiated. The setting has a range of 10 to 360 minutes and is factory set for 120 minutes. The inhibit time is started when the hopper is turned on, a new drying temperature is entered, or the setback option has been selected.

Setback display:

Selection of the setback option is shown on the main screen by an asterisk * prior to the hopper number.

Parenthesis around the setpoint temperature indicates the temperature has been setback. The setback temperature is then displayed.