

Closed Loop Conveying Accessories

DSV Discharge Selection Valve With Relief CLR Closed Loop Relief Vent

DSV - Discharge Selection Valve with Relief for Dry Air Conveying

- Requires a separate Relief Vent in a closed system.
- Includes 3-Bolt Coupler and pump adapter fitting.
- For use with either VRB or VPDB pumps.
- Control Voltage : 115 VAC or 24 VDC

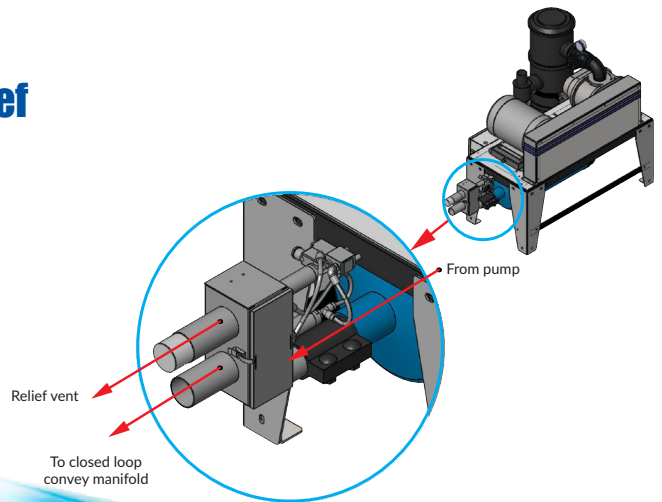

Pump Inlet Diameter in./mm	1.5/40	2.0/50	2.5/65	3.0/75	4.0/100
-------------------------------	--------	--------	--------	--------	---------

Closed Loop Conveying System Air Illustration

Closed loop conveying configuration illustrating use of discharge selection valve with relief vent.

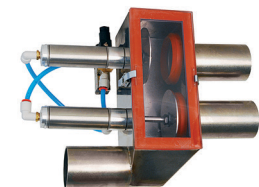
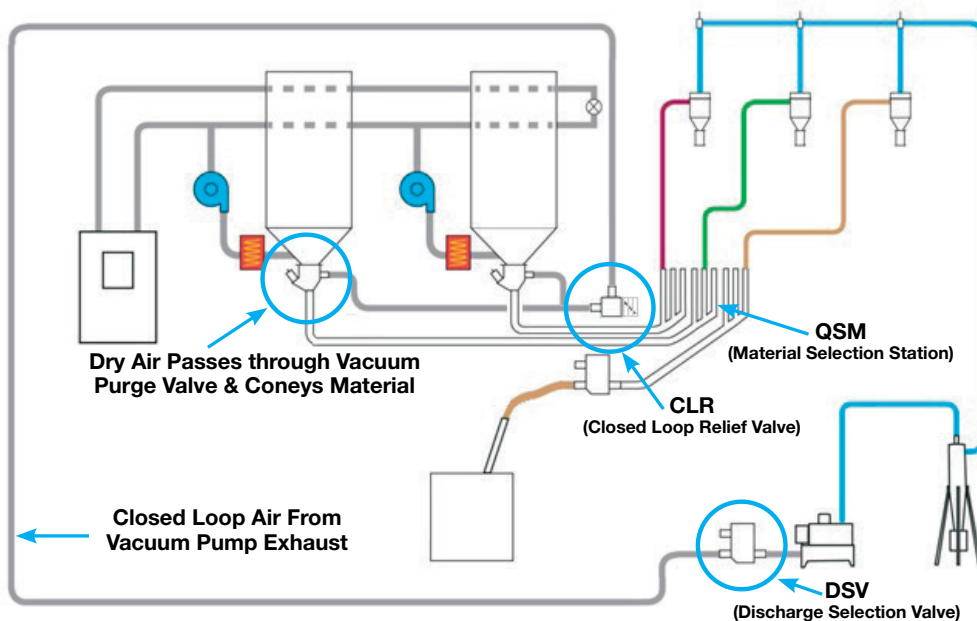

Discharge Selection Valve

DRI-AIR®
Industries, Inc.

 PROUDLY MADE IN THE USA

CLR - Closed Loop Relief Vent:

Provides pressure relief in a Closed Loop Conveying System.

- Install near take-off devices in a closed loop system.
- Install one per row of take-offs that share a common closed loop manifold.

Must specify outlet connection stub diameter of 1.5", 2", 2.5" or 3"

Inlet Diameter in./mm	1.5/40	2.0/50	2.5/65	3.0/75	4.0/100



CLR Closed Loop Valve
with Relief Vent

CLR Orientation on CDA (Central Drying Assembly)

